

# Aut-O-Loc™ 2 Installation Instructions

## List of contents in the box:

Description	Quantity
Aut-O-Loc™ 2	1 each
Instruction Set	1 each
Hardware packet containing:	1 each
Washer, Lock, 1/2"	2 each
Washer, Lock 5/8"	1 each
Nut, Nyloc, Hex 3/8"	1 each
Nut, Hex, 1/2"	2 each
Nut, Hex 5/8"	1 each
Bolt, 3/8" x 2-1/2"	1 each
Bolt, 1/2" x 2-1/4"	1 each
Bolt, 1/2" x 4"	1 each
Bolt, 5/8" x 4.25"	1 each
Clamp, Belt, Buckle	1 each
Clamp, Pipe (for belt buckle)	1 each

## Following is a list of necessary tools:

- 3/4 inch six or twelve point socket
- 3/4 inch combination open/box end wrench
- 9/16 inch socket
- 15/16 inch socket
- 5-100 ft lb torque wrench

## General Warnings

- Read all instructions prior to installation and use.
- This unit is not a person fall protection device.
- This unit must be replaced after catching a falling load.
- Ensure all people are clear of backstop when operating hoisting equipment.
- This unit is intended for indoor use only
- Use appropriate lock-out and tag-out procedure for backstop hoist when installing Autoloc™.
- During installation, use a tether on the Autoloc™ that will prevent the Autoloc™ from falling.
- Ensure that people are well clear of work area, and that no-one is underneath work platform. When installing unit ensure that work platform is stable and clear of moving equipment during hoist operation. Work platform (i.e. man lifts) may tip when extended to great heights. Make sure the work platform is clear of the backstop when testing the movement of the backstop and Autoloc™. Do not stand on work platform during movement of backstop.
- Belt must move freely through the range of backstop motion. Belt must not rub against anything as backstop moves; abrasion may cause Belt failure.
- Keep loose clothing, long hair and jewelry clear of equipment while installing Autoloc™.

Shown with universal 3" pipe or 4" tube clamp. (2" pipe & I-Beam mounts available)

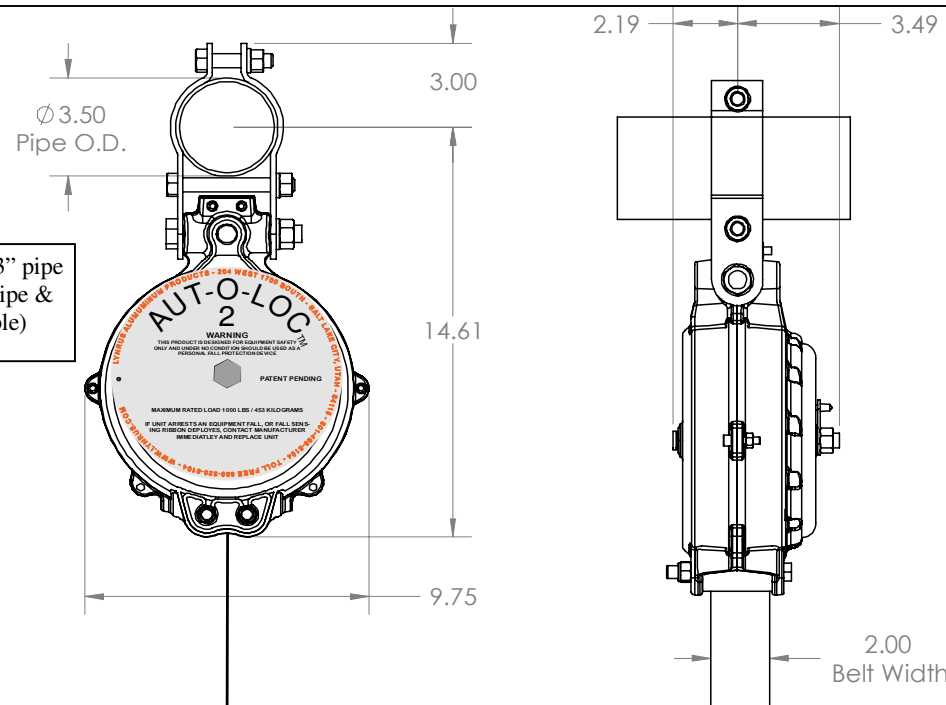

SHIPPING WEIGHT	22 LBS
CAPACITY	1000 LBS Max
TRAVEL	35 Feet Max
SPEED	100 ft/min Max

1. The basketball backstop must be in its deployed (down) position for installation of the Aut-O-Loc.
2. Locate the installation position of the Aut-O-Loc. It is important that you provide a minimum of 30" between the center point of the pipe where the Aut-O-Loc mounts and the center point of the belt attachment point on the backboard or mast. This is to allow clearance for the height of the Aut-O-Loc, the warning ribbon and attachment loop without creating any slack in the belt.

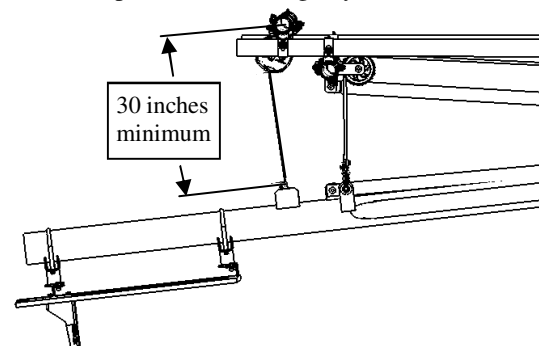

- 2.2 The Aut-O-Loc must be mounted in the center plane of backstop motion and the belt should not angle to the side or rub against any surface. Maximum belt side angle should not be greater than 1° at maximum belt payout.

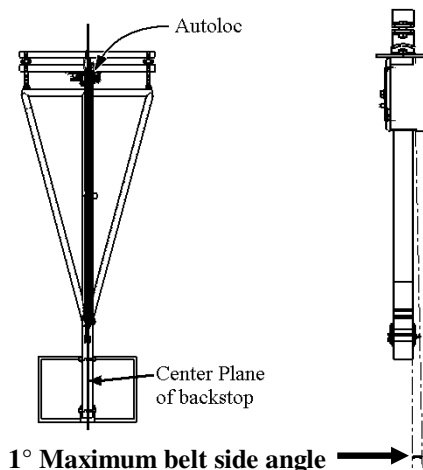

# Aut-O-Loc™ 2 Installation Instructions

**2.3** The Aut-O-Loc Belt should be clear of obstructions throughout its sweep. These angles are installation dependant

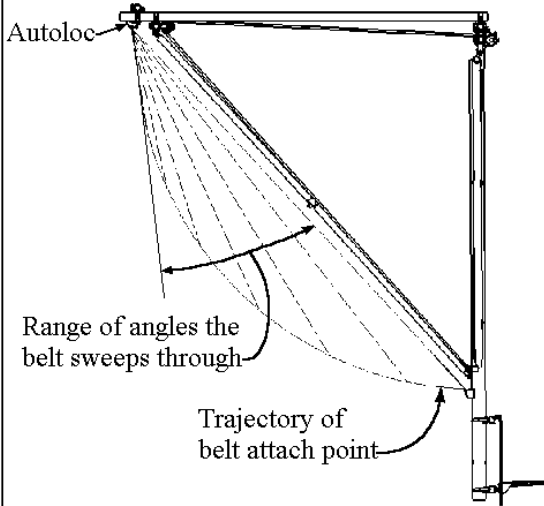

**3.** Insert 1/2 x 2.25" bolt in top clamp hole and finger tighten into opposite half clamp using 1/2" lock washer and nut. Place clamp over mounting pipe. Lift Aut-O-Loc unit up to clamp, insert 5/8" x 4.25" bolt through bottom hole in both clamp halves and Aut-O-Loc unit and finger tighten using 5/8" lock washer and nut. Insert 1/2" x 4" bolt in middle clamp hole and finger tighten using nut and lock washer. Position the Aut-O-Loc and hand tighten all bolts so that the Aut-O-Loc will remain in position on the pipe.

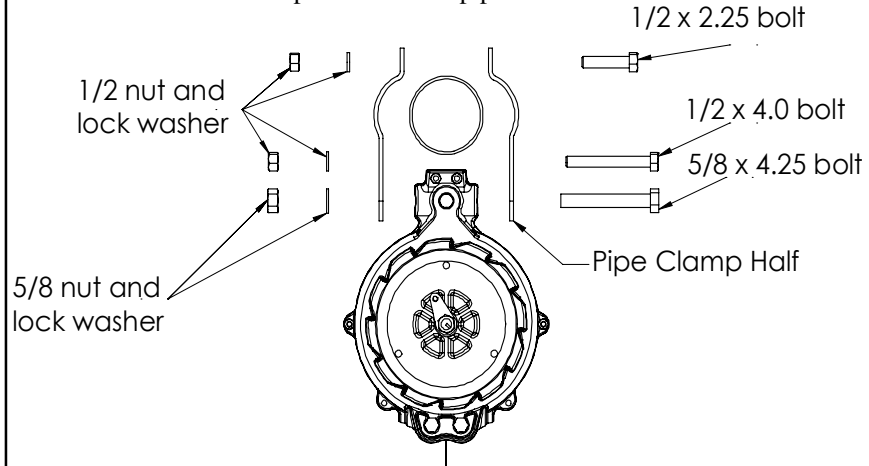

**4.** Stretch belt out and attach to mast. Use following steps to properly install belt clamp:

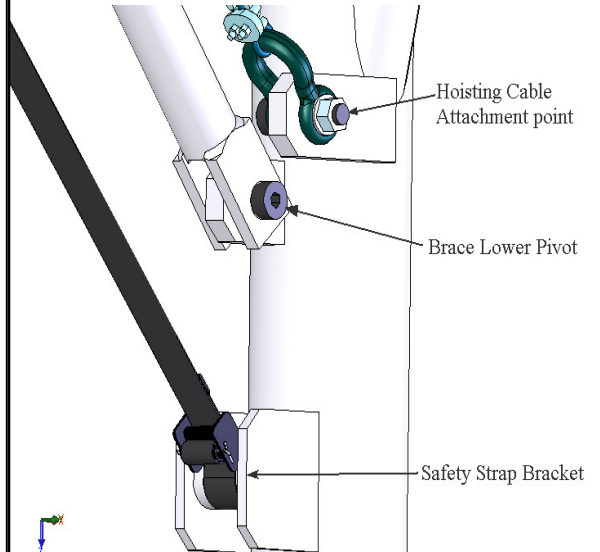

**5.** Wrap end around mast attach point. Place sewn tail of belt loop on the outside of the loop. Insert bolt through the clamp and clamp tube and tighten Nyloc nut on opposite side.

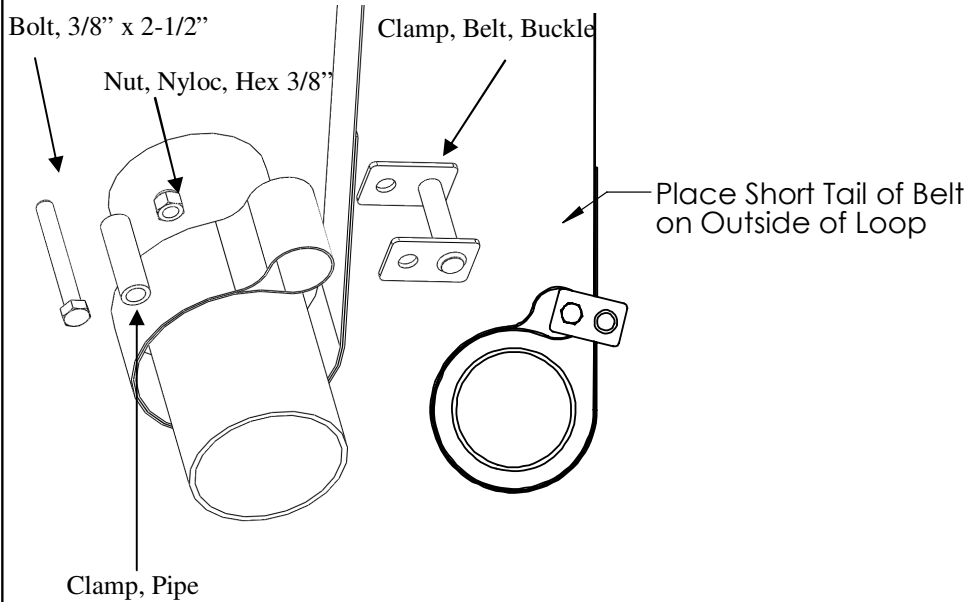

**6.** Tighten the top and middle 1/2" clamp nuts to a torque of 35 ft lbs.

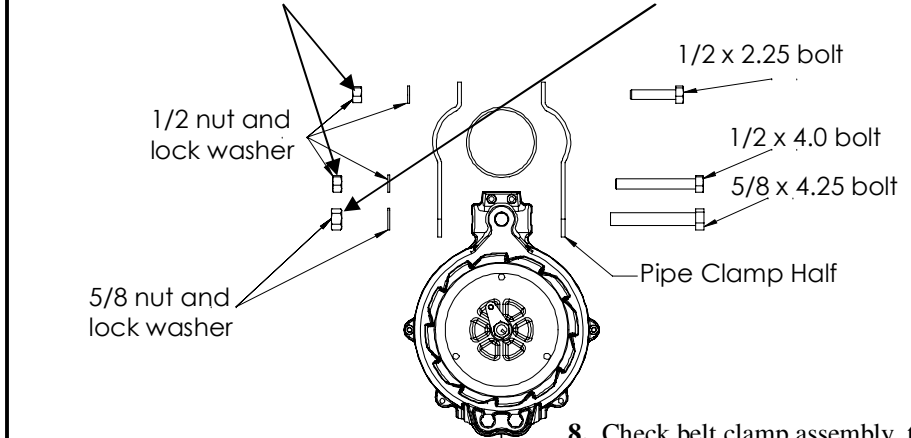

**7.** Tighten the Bottom 5/8" clamp nut to a torque of 45 ft lbs.

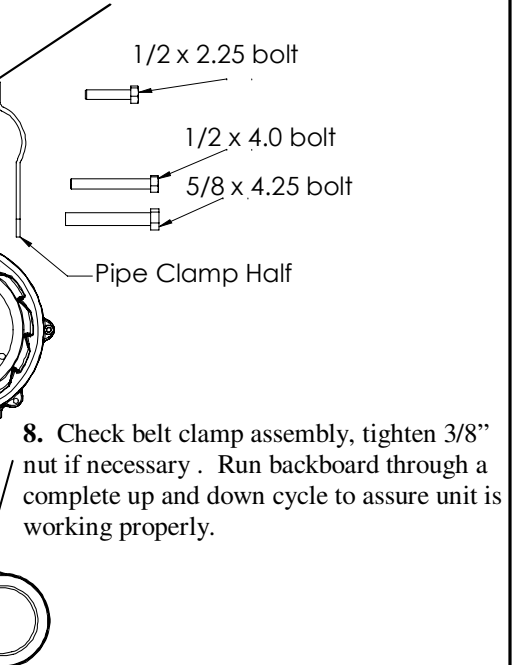

**8.** Check belt clamp assembly, tighten 3/8" nut if necessary. Run backboard through a complete up and down cycle to assure unit is working properly.